

# A population genetic comparison of large- and small-bodied sage grouse in Colorado using microsatellite and mitochondrial DNA markers

S. J. OYLER-McCANCE,\* N. W. KAHN,† K. P. BURNHAM,‡ C. E. BRAUN§ and T. W. QUINN¶

\*Department of Fishery and Wildlife Biology, Colorado State University, Fort Collins, CO 80523, USA, †Department of Biochemistry and Molecular Genetics, University of Colorado Health Sciences Centre, Denver, CO 80262, USA, ‡Colorado Cooperative Fish and Wildlife Research Unit, Colorado State University, Fort Collins, CO 80523 USA, §Colorado Division of Wildlife, Fort Collins, CO 80526 USA, ¶Department of Biological Science, University of Denver, Denver CO 80208, USA

## Abstract

Sage grouse (*Centrocercus urophasianus*) from southwestern Colorado and southeastern Utah (United States) are 33% smaller than all other sage grouse and have obvious plumage and behavioural differences. Because of these differences, they have been tentatively recognized as a separate 'small-bodied' species. We collected genetic evidence to further test this proposal, using mitochondrial sequence data and microsatellite markers to determine whether there was gene flow between the two proposed species. Significant differences in the distribution of alleles between the large- and small-bodied birds were found in both data sets. Analysis of molecular variance (AMOVA) revealed that 65% of the variation in mitochondrial DNA (mtDNA) haplotypes could be explained by the large- vs. small-bodied distinction. Genetic distances and neighbour-joining trees based on allelic frequency data showed a distinct separation between the proposed species, although cladistic analysis of the phylogenetic history of the mitochondrial sequence haplotypes has shown a lack of reciprocal monophyly. These results further support the recognition of the small-bodied sage grouse as a distinct species based on the biological species concept, providing additional genetic evidence to augment the morphological and behavioural data. Furthermore, small-bodied sage grouse had much less genetic variation than large-bodied sage grouse, which may have implications for conservation issues.

**Keywords:** Colorado, gene flow, microsatellites, mtDNA, sage grouse, speciation

Received 26 November 1998; revision received 12 March 1999; accepted 1 April 1999

## Introduction

Historically, sage grouse (*Centrocercus urophasianus*) occurred in at least 15 states and three provinces in North America (Aldrich 1963; Johnsgard 1973). They have since been extirpated from three states and one province (Johnsgard 1973) and their range has declined markedly elsewhere (Braun *et al.* 1994). Declines have also occurred in Colorado where they have been extirpated from 12 of the 27 counties in which they occurred in the 1900s (Braun 1995) and populations in nine of the remaining 15 counties are thought to include fewer than 500 breeding

birds. Because of this marked decline, sage grouse have become a focus of management and conservation concerns.

Sage grouse have historically been classified into two subspecies: *C. urophasianus urophasianus* (Eastern sage grouse) and *C. urophasianus phaios* (Western sage grouse). This distinction was based on plumage and colouration differences (Aldrich & Duvall 1955), yet its validity has been questioned (Johnsgard 1983). Within the range of the Eastern sage grouse, Hupp & Braun (1991) and Barber (1991) found sage grouse in southwestern Colorado and southeastern Utah to be  $\approx 33\%$  smaller than those from northern Colorado and throughout the rest of the entire species' range. These 'small-bodied' sage grouse have longer filoplumes, different tail banding patterns and distinct ritualized strut displays compared with representative 'large-bodied' sage grouse populations in northern

Correspondence: S. J. Oyler-McCance, 201 Wagar, Department of Fishery and Wildlife Biology, Colorado State University, Fort Collins, CO 80523, USA. Fax: 970-491-1413 E-mail: soyler@lamar.colostate.edu

Colorado and California (Young 1994; Young *et al.* 1994). Furthermore, Young (1994) found that small-bodied females avoided tape-recorded vocalizations of large-bodied males. Based on these considerable morphological and behavioural differences, Braun & Young (1995) proposed that small-bodied sage grouse from southwestern Colorado and southeastern Utah be recognized as a new species, based on the biological species concept.

To determine whether genetic evidence is consistent with this new species designation, Kahn *et al.* (1999) compared genetic variation among five populations of large-bodied sage grouse from northern Colorado, one population of large-bodied sage grouse from Utah and one population of small-bodied sage grouse from southwestern Colorado. To document this variation, they sequenced 141 base pairs (bp) of a rapidly evolving portion (region I) of mitochondrial DNA (mtDNA) and showed that sequences from the seven populations included 21 haplotypes that formed two monophyletic clades. Several different haplotypes from both clades were found in all six large-bodied populations while, within the small-bodied population, all but one of 31 individuals were genetically identical, and both observed haplotypes were members of the same clade. They concluded that the unusually low level of genetic variation and absence of several haplotypes that were common in the large-bodied populations in Colorado provided evidence of a lack of gene flow between the two proposed species.

While the study of Kahn *et al.* (1999) provides evidence that can be construed to support the new species designation, we expanded it to include individuals from three additional small-bodied populations and supplemented their mtDNA data with data from (nuclear) microsatellites. This was carried out to characterize the mtDNA data in more detail and to eliminate any concern that

male-biased gene flow would not be elucidated using the maternally inherited (mitochondrial) markers. Microsatellites are highly variable and are generally considered to be among the most powerful molecular genetic markers for population genetic studies (Goldstein & Pollock 1997).

## Materials and methods

### Tissue collection

DNA extracted from 20 birds from the Gunnison Basin and from the five large-bodied populations in Colorado that were used in the study of Kahn *et al.* (1999), were also used in this study. We did not include their samples or data from Utah. The five northern Colorado populations included Cold Springs, Blue Mountain, Eagle, Middle Park and North Park (Fig. 1). Additional blood samples and feathers were obtained from small-bodied sage grouse captured using a spotlight trapping method (Giesen *et al.* 1982) in the following populations in Colorado: Dove Creek ( $n = 15$ ), Dry Creek Basin ( $n = 22$ ), Crawford ( $n = 20$ ) and Gunnison Basin ( $n = 9$ ) (Fig. 1). Blood samples were obtained by clipping a toe nail and collecting two to three drops in a microfuge tube previously coated with EDTA. These blood samples, and feathers from each bird, were frozen at  $-20^{\circ}\text{C}$ . The nine Gunnison Basin samples were from the same area sampled by Kahn *et al.* (1999) and were used to augment the 20 Gunnison Basin samples collected by them.

### DNA extractions and microsatellite genotype scoring

DNA extractions from blood or the basal 2 cm of the feather shaft (slit vertically), followed the procedure of Quinn & White (1987). More than 30 microsatellite

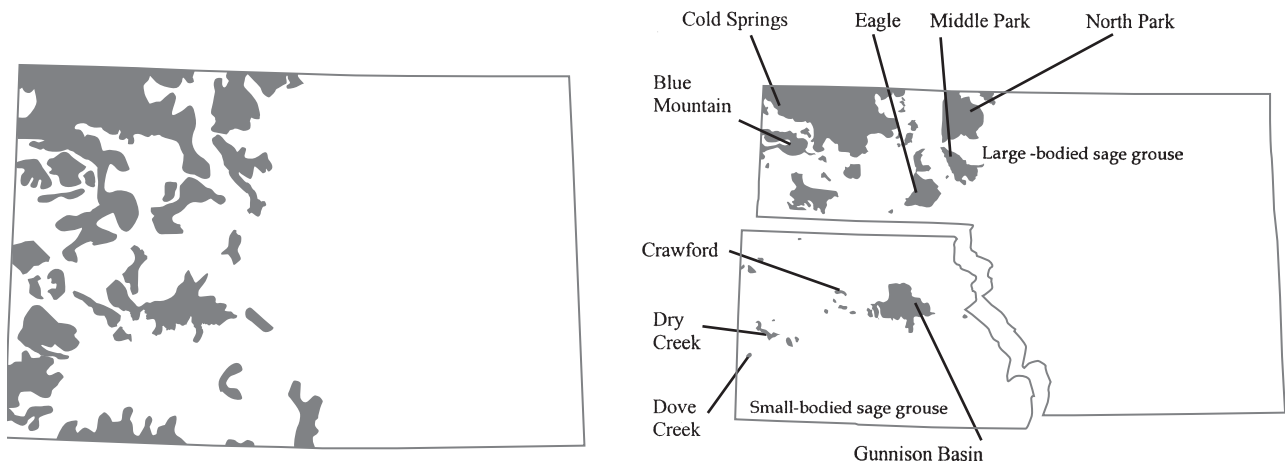

**Fig. 1** Historic (left) and current (right) distribution of large- and small-bodied sage grouse and sample locations in Colorado. The boundary between the ranges of large- and small-bodied birds is shown on the right.

primer pairs from the chicken genome project (Cheng *et al.* 1995) and 12 primer pairs developed for red grouse (*Lagopus lagopus scoticus*) were used to screen birds for polymorphism. We found four microsatellites with clean, scorable products that were polymorphic in both the large and small-bodied sage grouse. Primers for these four microsatellites (LLST1F, LLST1R, LLSD3F, LLSD3R, LLSD4F, LLSD4R, LLSD8F and LLSD8R) were developed by Piertney & Dallas (1997). For later visualization on autoradiography film, one primer of each pair was radioactively end-labelled with  $\gamma^{32}\text{P}$  using T4 polynucleotide kinase according to the manufacturer's (Pharmacia) specifications.

The polymerase chain reaction (PCR) was performed in a Perkin-Elmer DNA thermal cycler. Approximately 30 ng of genomic DNA (in a 1- $\mu\text{L}$  volume) was used as template in each 25- $\mu\text{L}$  PCR (as described in Quinn 1992), using one forward and one reverse primer, with the following thermal profile: 2 min denaturation at 94 °C followed by 35 cycles of 'touchdown' ramping—30 s denaturation at 94 °C and 30 s annealing while stepping from 60 °C to 50 °C (we did not include an extension step in the touchdown procedure). A 20-min extension at 74 °C was performed at the end of the 35th cycle.

Microsatellite PCR products and a size standard were electrophoresed at 55 watts for 2 h through 6% denaturing polyacrylamide gels (plate length = 48.5 cm) as described in Sambrook *et al.* (1989). Autoradiographs were made of each dried acrylamide gel by exposure to X-ray film (Fuji RX). Individuals were assigned genotypes (corresponding to fragment length) based on banding patterns on the autoradiographs. In some cases, samples containing alleles of similar sizes were rerun in adjacent lanes. The distribution of allele frequencies for each population was recorded.

#### mtDNA sequencing

mtDNA procedures were carried out as described previously (Kahn *et al.* 1999).

#### Data analysis

Microsatellite genotypes were tested for departure from Hardy-Weinberg equilibrium within each population at each locus using the computer program ARLEQUIN (Schneider *et al.* 1997). ARLEQUIN employs a Markov-chain random walk algorithm (Guo & Thompson 1992), which is analogous to Fisher's exact test but extends it to an arbitrarily sized contingency table. Population genetic structure was investigated using pairwise population  $F_{ST}$  significance tests.  $F$ -tests (Tjor 1998) for each locus were conducted to determine whether the distributions of alleles were significantly different between the large- and small-bodied birds. An  $F$ -test is a ratio of mean squares

(analogous to analysis of variance, ANOVA), which is used here because it is robust to overdispersed data.

Genetic distance for all pairs of populations was estimated using two different distance metrics. The first metric, the proportion of alleles shared (Bowcock *et al.* 1994), assumes an infinite alleles model of mutation. Although Goldstein & Pollock (1997) advocate using stepwise mutation models to estimate genetic distances for phylogenetic reconstruction using microsatellite data, Goldstein (personal communication) suggests that population genetic studies using microsatellites should use genetic distances based on the infinite alleles model—specifically the proportion of shared alleles (Bowcock *et al.* 1994)—because they are linear over short periods of time and have a low variance. We also calculated Cavalli-Sforza & Edwards's (1967) chord distance because Takezaki & Nei (1996) showed it to have a higher probability of obtaining correct tree topologies than other distance measures with microsatellite markers. We calculated genetic distance between all pairs of populations and constructed neighbour-joining trees, describing the relationship among populations using the microsatellite data and the two distance measures.

We analysed the mtDNA sequences in two different ways: by unique haplotypes and by haplotype frequencies within populations. Maximum parsimony analyses were performed on the unique haplotypes using the heuristic search algorithm of PAUP 3.0 (Swofford 1991). Details of this analysis are given in Kahn *et al.* (1999). For the population analysis, we documented population subdivision in ARLEQUIN (Schneider *et al.* 1997) using significance tests of pairwise population  $F_{ST}$  values. An  $F$ -test was calculated to determine whether the distribution of haplotypes among the large- and small-bodied birds differed. We conducted an analysis of molecular variance (AMOVA), as described by Excoffier *et al.* (1992), which produces estimates of variance components to reflect haplotype diversity at different levels of a hierarchy. We documented the variation of large- vs. small-bodied birds as one level of hierarchy, the variation among populations within the two body sizes as a second level, and the variation among individuals in a population as the third level. The molecular distances between haplotypes were modelled following Tamura (1992) because our haplotypes had unequal frequencies of A, C, G and T and because the observed transition/transversion ratio was much higher than the expected (mathematically) ratio of 1:2. We calculated pairwise population genetic distances that incorporated both the Tamura (1992) corrected molecular distance between haplotypes and the haplotype frequencies in each population. Neighbour-joining trees were constructed showing the relationship of the nine populations according to allelic distribution and frequency.

**Table 1** Polymorphism of microsatellite loci among all nine populations of sage grouse in Colorado

Population	Mean sample size per locus (SD)	Mean no. of alleles per locus (SD)	Polymorphic loci (SD)	Mean heterozygosity	
				Observed (SD)	Expected from Hardy–Weinberg
Small-bodied birds					
Gunnison Basin	28.5 (0.5)	3.8 (1.4)	75	0.386 (0.123)	0.374 (0.120)
Crawford	17.3 (0.6)	2.3 (0.6)	75	0.299 (0.138)	0.297 (0.151)
Dry Creek	17.5 (1.6)	2.5 (0.6)	50	0.179 (0.135)	0.283 (0.177)
Dove Creek	14.5 (0.3)	1.8 (0.5)	50	0.193 (0.135)	0.221 (0.142)
Large-bodied birds					
Cold Springs	20.5 (0.6)	5.5 (2.5)	100	0.631 (0.118)	0.611 (0.114)
Blue Mountain	21.5 (1.2)	6.5 (3.2)	100	0.596 (0.120)	0.600 (0.144)
North Park	22.8 (1.0)	5.5 (2.2)	100	0.643 (0.080)	0.619 (0.098)
Middle Park	19.3 (0.8)	5.5 (1.6)	100	0.701 (0.089)	0.639 (0.078)
Eagle	20.3 (0.8)	5.5 (2.5)	100	0.748 (0.145)	0.636 (0.103)

## Results

### Microsatellite data

We found several alleles at each of the four microsatellite loci (Table 1). The small-bodied sage grouse exhibited much less polymorphism with the average number of alleles per locus ranging from 1.8 to 3.8 compared to the large-bodied sage grouse with an average of 5.5–6.5 alleles per locus. Furthermore, all loci among the large-bodied birds were polymorphic, while in some small-bodied populations either one or two loci were monomorphic. Only two of the 33 population–locus combinations showed significant departures ( $P < 0.05$ ) from Hardy–Weinberg equilibrium (Dry Creek locus LLSD3,  $P = 0.008$  and Eagle locus LLSD3,  $P = 0.0004$ ). Because we made 36 comparisons, we might obtain a  $P$ -value of 0.008 by chance, so we set our significance level at 0.001, leaving only one significant departure from Hardy–Weinberg equilibrium (Eagle, LLSD3).

Pairwise population  $F_{ST}$  significance tests showed significant population subdivision. Owing to multiple comparisons within the analysis, we decreased our  $P$ -value by a factor of 10 to 0.005 to indicate statistical significance. All possible pairwise comparisons between small- and large-bodied sage grouse populations showed significant differences. Within the large-bodied sage grouse, no two populations were significantly different, while among the small-bodied birds, only two population pairs were not significantly different (Gunnison and Dry Creek,  $P = 0.0073$ ; Dry Creek and Dove Creek,  $P = 0.025$ ). Furthermore, we calculated  $F_{ST}$  values separately for the large- and small-bodied populations. We found that the large-bodied birds had much less population subdivision ( $F_{ST} = 0.0266$ , 95% CI 0.0016–0.0528) than did the small-bodied birds ( $F_{ST} = 0.2153$ , 95% CI 0.1230–0.3339).

At each microsatellite locus we compared the distribution of alleles between the large- and small-bodied birds and found that three loci showed a significant difference (LLSD3  $F_{6,30} = 5.95$ ,  $P < 0.001$ ; LLSD4  $F_{32,146} = 2.51$ ,  $P < 0.001$ ; LLSD8  $F_{3,15} = 102.05$ ,  $P < 0.001$ ) and one did not (LLST1  $F_{3,15} = 0.983$ ,  $P > 0.05$ ). While the topologies of the trees from the different distance measures differed slightly (Fig. 2a), the main pattern of the distinction between the large- and the small-bodied birds was evident.

### Mitochondrial data

There were 19 different haplotypes across all individuals. Accession nos for these sequences have been entered in the GenBank sequence database as previously described in Kahn *et al.* (1999). They found that the five large-bodied populations from Colorado all had at least five different haplotypes in each population. They found four dominant haplotypes (A, B, C and D) with haplotypes B, C and D common in all large-bodied populations and haplotype A found in all but one (Fig. 3). In the small-bodied populations, we found only two or three haplotypes per population. Only one of the haplotypes dominant in the large-bodied birds, A, was found and haplotype G was found to be unique among the small-bodied birds (Fig. 3). Haplotype AI, while not found in large-bodied birds in Colorado, was found in one large-bodied bird from Utah (Kahn *et al.* 1999).

We found 144 equally parsimonious trees using maximum parsimony analysis, with consensus showing two deep clades of haplotypes (Fig. 4). Within each clade, haplotypes were much less divergent (average = 2.0% sequence divergence) than between the two clades (average = 17.5%). The topology of this tree was similar to one produced by neighbour-joining analysis. Haplotypes from the large-bodied birds were found in both clades,

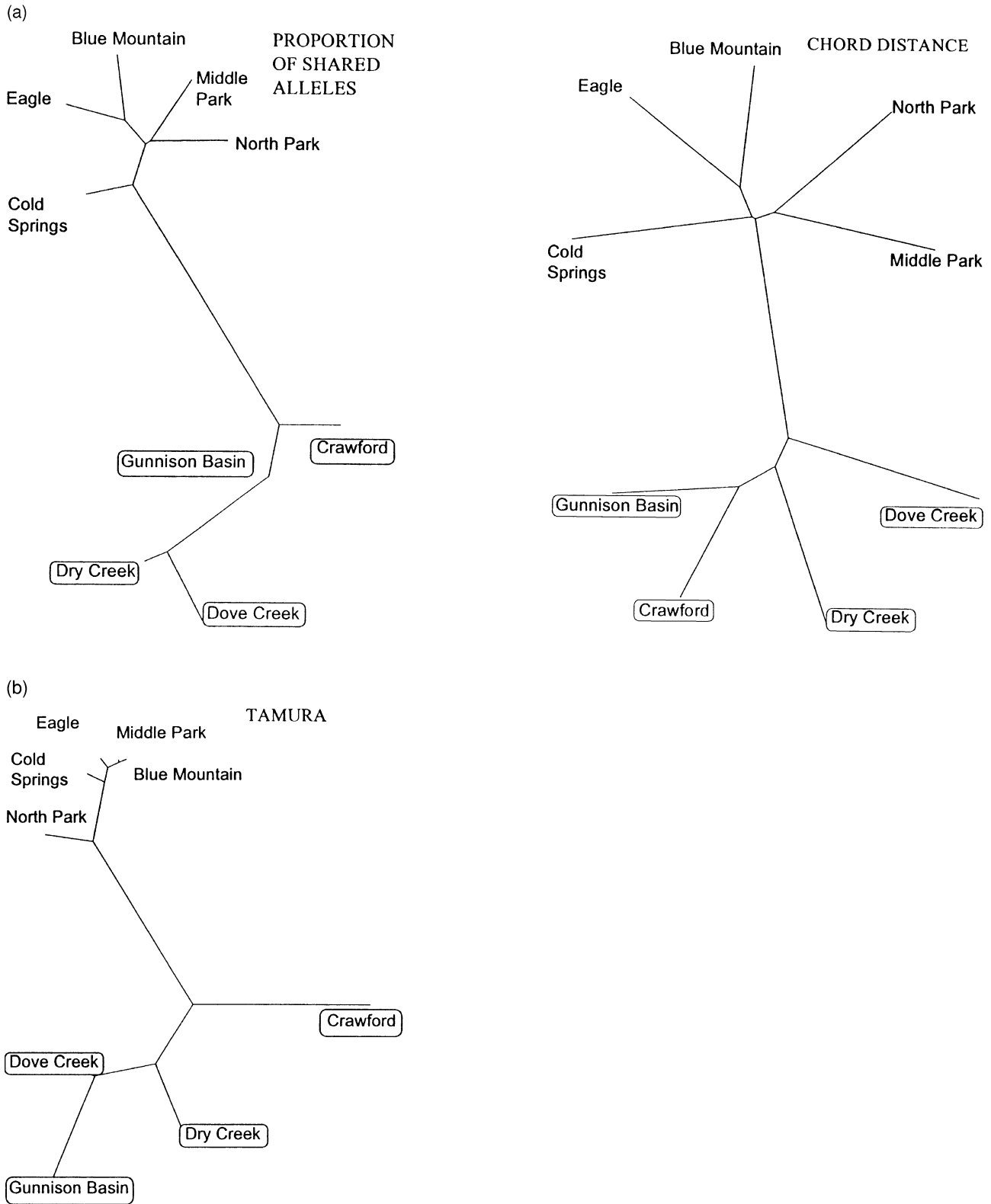

Fig. 2 (a) Neighbour-joining trees of microsatellite data using two different genetic distance measures. Small-bodied populations are identified by a box around the name. (b) Neighbour-joining tree of mitochondrial DNA (mtDNA) genetic distances calculated using allele frequencies and haplotype distances (Tamura 1992). Small-bodied populations are identified by a box around the name.

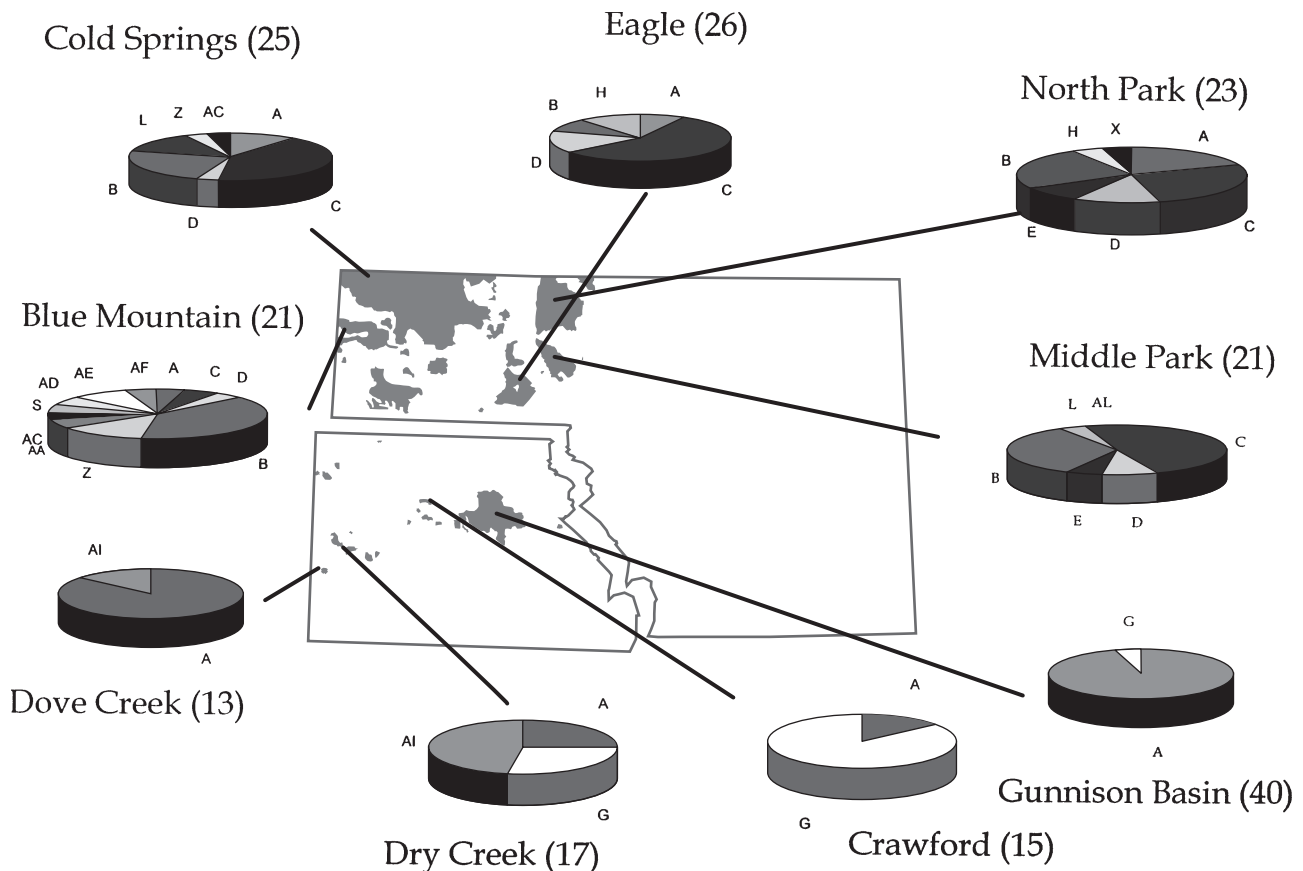

Fig. 3 Mitochondrial DNA (mtDNA) haplotypes among nine sage grouse populations in Colorado. The lower left cut-out represents the range of the small-bodied sage grouse. Sample sizes are in parentheses.

while haplotypes from the small-bodied birds were found only in one clade.

We found significant population subdivision using population pairwise  $F_{ST}$  significance tests. As with the microsatellite data, all possible pairwise comparisons between small- and large-bodied sage grouse populations showed significant differences. Furthermore, we found that within the large-bodied sage grouse, no two populations were significantly different and among the small-bodied sage grouse, only one population pair was not significantly different (Dry Creek and Dove Creek,  $P = 0.072$ ). To test whether the distribution of haplotypes from the large-bodied populations differed from the distribution of haplotypes from the small-bodied populations, we used an  $F$ -test. There was a statistically significant difference between the distribution of haplotypes in the large- and small-bodied populations ( $F_{18,70} = 3.82$ ,  $P < 0.001$ ). Furthermore, we used AMOVA to examine components of variance between the large- and small-bodied groups, among the populations within groups, and among individuals within populations. We found that while 65% of the variance could be explained by the large- vs. small-bodied group distinction, only 2% of the

variance was explained by between-population variation within body size, and the remaining 33% of the variance was explained by within-population variation. The pattern observed in the trees from the microsatellite data was similar to the population mtDNA tree (Fig. 2b), suggesting a separation between the large- and small-bodied sage grouse.

## Discussion

In all four microsatellites, and in the 141-bp control region of the mtDNA, high variability was found even at our smallest hierarchical level of sampling (within populations), which provided us with a powerful tool for detecting population subdivision. The only significant departure from Hardy–Weinberg equilibrium (Eagle locus LLS3) was a case of heterozygote deficiency, which could be the result of many factors including null alleles, the Wahlund effect and inbreeding. Null alleles occur when a mutation causes one oligonucleotide primer not to amplify one allele, which is manifested by a deficiency of heterozygotes (Pemberton *et al.* 1995). We doubt that null alleles were the cause of the heterozygote

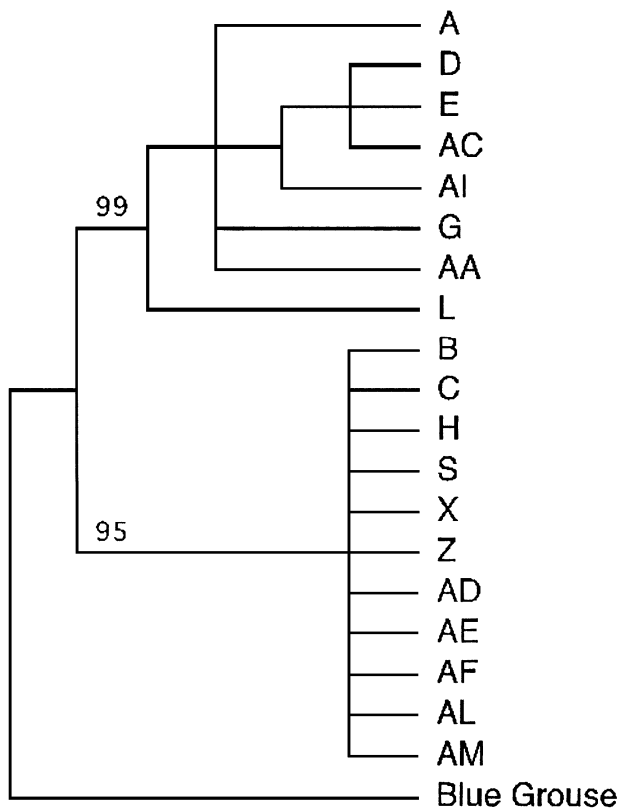

Fig. 4 Strict consensus tree of Colorado mitochondrial DNA (mtDNA) haplotypes. Trees derived using maximum parsimony analysis separate the 19 haplotypes into two deep monophyletic clades; bootstrap values for the two clades are shown.

deficiency in Eagle because we had no problem in obtaining PCR products from Eagle individuals for any locus, and because none were detected in two family groups of known mother and offspring, which were tested over all loci. Furthermore, a heterozygote deficiency was found only in one population and we might expect to find deficiencies in other populations if null alleles were the cause. The heterozygote deficiency in Eagle might thus have been caused by the Wahlund effect of pooling separate populations into one population, or by inbreeding. However, if either was the case we would have expected to find this effect among the three other loci, which we did not.

Pairwise population  $F_{ST}$  significance tests showed similar patterns in the microsatellite and mtDNA analyses of the large-bodied populations. Both markers revealed that there were no significant differences among any of the large-bodied populations, and  $F_{ST}$  among these populations was low (0.0266, 95% CI 0.0016–0.0528). This suggests substantial gene flow among populations.

Within the small-bodied bird populations, the majority of pairwise population comparisons showed significant differences among populations, with a few exceptions

(Gunnison and Dry Creek  $P = 0.007$ , Dry Creek and Dove Creek  $P = 0.025$  for microsatellites; Dry Creek and Dove Creek  $P = 0.054$  for mtDNA).  $F_{ST}$  calculated among the small-bodied populations was much greater than among the large-bodied birds ( $F_{ST} = 0.2153$ , 95% CI 0.1230–0.3339), suggesting that there is some subdivision among the small-bodied birds, probably because of their small population sizes ( $\approx 2600$  birds in Gunnison Basin,  $\approx 175$  birds in Crawford,  $\approx 75$  birds in Dove Creek and  $\approx 300$  birds in Dry Creek) (C. E. Braun, Colorado Division of Wildlife, unpublished data) and isolation (Fig. 1). This is consistent with Braun's (1995) assertion that clearing sagebrush for cultivated crops, highway construction, ranch development, powerline placement, reservoir construction and other facets of human settlement have resulted in the fragmentation and loss of sagebrush habitats such that sage grouse populations in southwestern Colorado are small and isolated. This reduction of habitat is evident when comparing the historic range of sage grouse in Colorado with its current distribution (Fig. 1). A comparison of these two distributions reveals that the majority of fragmentation and loss of habitat has occurred in southwestern Colorado, resulting in small, isolated populations, and that populations in northern Colorado remain relatively large and contiguous, all of which is supported by our genetic data.

Pairwise population  $F_{ST}$  significance tests revealed significant frequency differences between all large- vs. small-bodied population comparisons, supporting a distinction between these two groups of birds. The three of four significant  $F$ -tests for the microsatellite loci, and the significant  $F$ -test for the mtDNA data, reveal that the distribution of allele and haplotype frequencies are different for the large- and small-bodied sage grouse populations. Furthermore, in both the microsatellite and mtDNA data there are alleles and a haplotype unique to the small-bodied sage grouse, thereby supporting the idea that gene flow between the two groups is probably absent and some divergence has occurred. This is consistent with Braun & Young's (1995) recognition of small-bodied sage grouse as a new species, based on the biological species concept. In addition, the mtDNA AMOVA indicates that 65% of the total variation in the mtDNA data can be explained by the large- vs. small-bodied sage grouse distinction and that only 2% of the variation can be attributed to differences among populations within the large- or small-bodied group.

Measures of genetic distance show a similar broad distinction between large- and small-bodied populations for both mitochondrial and nuclear markers (Fig. 2a,b). The arrangement of the populations within the large- and small-bodied groups changes slightly using different distance measures. From the mtDNA tree based on haplotype frequencies we can conclude that within the

large-bodied group, populations are more closely related (shorter branch lengths) than within the small-bodied group (longer branch lengths) (Fig. 2b). This was also apparent from the pairwise population  $F_{ST}$  significance tests in which populations within the large-bodied group were not significantly different, whereas within the small-bodied group they were.

A phylogenetic analysis of mtDNA haplotypes revealed two deep clades and shallow branches within each (Kahn *et al.* 1999; Fig. 2). Haplotypes from large-bodied birds were distributed among both clades, while haplotypes from the small-bodied birds were found only in one of the two deep clades. Kahn *et al.* (1999) suggest that the tree shape is indicative of an ancestral isolation of sage grouse into two distinct populations during which monophyly was attained within each. Since then, extensive intermixing between the two previously isolated populations presumably led to the biogeographical pattern now observed among the large-bodied birds. They professed two different explanations for the establishment of the small-bodied sage grouse. Either a founder population of large-bodied birds diverged rapidly from other large-bodied populations, probably as a result of sexual selection, or the small-bodied sage grouse evolved across a more widespread portion of the southwestern range (remaining unnoticed as a separate taxon) and underwent severe bottlenecks, recently, as a result of habitat fragmentation and habitat loss.

Our data are consistent with the founder hypothesis because in the microsatellite analysis the majority of the alleles present in the small-bodied populations are also present in the large-bodied populations, yet the diversity in the small-bodied populations (17 alleles) is much less than in the large-bodied populations (44 alleles). The mtDNA analysis also supports this hypothesis in that the dominant haplotype in the small-bodied populations (A) is well represented in the large-bodied birds. The haplotype unique to the small-bodied birds (G) is close to the A haplotype (one transition), representing a recent mutation. As in the microsatellite analysis, genetic diversity in the large-bodied populations is much higher (17 haplotypes) than in the small-bodied populations (three haplotypes).

To investigate the bottleneck hypothesis, we used Luikart & Cornuet's (1998) premise that in populations recently bottlenecked, the mutation drift equilibrium is disturbed, resulting in an increase in the number of heterozygotes. This heterozygote excess results from the fact that alleles are lost rapidly (in particular rare alleles) during a bottleneck with little effect on heterozygosity. Therefore, many alleles can be lost without much reduction in heterozygosity. Although we did not have sufficient loci to test this directly using Cornuet & Luikart's (1996) statistical test, we found that only one locus had a number of heterozygotes greater than that expected by Hardy-

Weinberg equilibrium, and the difference between observed and expected values was only 0.54. Thus, we doubt that the small-bodied birds underwent a severe, range-wide bottleneck unless the bottleneck occurred and had sufficient time to again reach mutation drift equilibrium.

This study has provided valuable additional data to the results of Kahn *et al.* (1999) in that we now have nuclear data to corroborate the mtDNA data. Furthermore, we have expanded the survey of small-bodied birds to include information from three additional populations, which is essential for the conservation of the small-bodied sage grouse. We have not only extended Kahn *et al.*'s (1999) picture of the distinction between large- and small-bodied sage grouse, but we have documented the isolation and low genetic diversity of the small-bodied sage grouse populations. This is important information for the management of the small-bodied sage grouse as a species. Future research on sage grouse should include more microsatellite loci and population surveys throughout the entire range of sage grouse. This would provide a much deeper knowledge base for the understanding and management of sage grouse.

### Acknowledgements

Many individuals participated in the field studies of Gunnison sage grouse in Colorado. We recognize, in particular, the contributions of M. L. Commons, J. W. Hupp and J. R. Young. The capture of birds was under permit from the Colorado Division of Wildlife (CDOW), and handling and sample collection followed protocols of the CDOW's Animal Use and Care Committee. Funding was from Colorado Federal Aid in Wildlife Restoration Project W-167-R through the Colorado Cooperative Fish and Wildlife Research Unit. We also thank N. Benedict and S. Tuggle for their helpful comments on this manuscript.

### References

- Aldrich JW (1963) Geographic orientation of American Tetraonidae. *Journal of Wildlife Management*, **27**, 529–545.
- Aldrich JW, Duvall JW (1955) *Distribution of American Gallinaceous Game Birds*. Circular 34, United States Department of Interior, Fish and Wildlife Service, Washington, DC.
- Barber HA (1991) *Strutting behavior, distribution and habitat selection of sage grouse in Utah*. MS Thesis, Brigham Young University.
- Bowcock AM, Ruiz-Linares A, Tomfohrde J, Minch E, Kidd JR, Cavalli-Sforza LL (1994) High resolution of human evolutionary trees with polymorphic microsatellites. *Nature*, **368**, 455–457.
- Braun CE (1995) Status and distribution of sage grouse in Colorado. *Prairie Naturalist*, **27**, 1–9.
- Braun CE, Young JR (1995) A new species of sage grouse in Colorado. Abstract no. 23. In: *Joint Meeting Wilson Ornithological Society and the Virginia Society of Ornithology*, May 4–7, 1995. Williamsburg, VA.
- Braun CE, Martin K, Remington TE, Young JR (1994) North American grouse: issues and strategies for the 21st Century. *Transactions of the North American Wildlife and Natural Resources Conference*, **59**, 428–438.

- Cavalli-Sforza LL, Edwards AWF (1967) Phylogenetic analysis: models and estimation procedures. *American Journal of Human Genetics*, **19**, 233–257.
- Cheng HH, Levin I, Vallejo RL *et al.* (1995) Development of a genetic map of the chicken with markers of high utility. *Poultry Science*, **74**, 1855–1874.
- Cornuet JM, Luikart G (1996) Description and evaluation of two tests for detecting recent bottlenecks. *Genetics*, **144**, 2001–2014.
- Excoffier L, Smouse PE, Quattro JM (1992) Analysis of molecular variance inferred from metric distances among DNA haplotypes: application to human mitochondrial DNA restriction data. *Genetics*, **131**, 479–491.
- Giesen KM, Schoenberg TJ, Braun CE (1982) Methods for trapping sage grouse in Colorado. *Wildlife Society Bulletin*, **10**, 224–231.
- Goldstein DB, Pollock DD (1997) Launching microsatellites. *Journal of Heredity*, **88**, 335–342.
- Guo S, Thompson E (1992) Performing the exact test of Hardy–Weinberg proportions for multiple alleles. *Biometrics*, **48**, 361–372.
- Hupp JW, Braun CE (1991) Geographic variation among sage grouse in Colorado. *Wilson Bulletin*, **103**, 255–261.
- Johnsgard PA (1973) *Grouse and Quails of North America*. University of Nebraska Press, Lincoln.
- Johnsgard PA (1983) *Grouse of the World*. University of Nebraska Press, Lincoln.
- Kahn NW, Braun CE, Young JR, Wood S, Mata DR, Quinn TW (1999) Molecular analysis of genetic variation among large- and small-bodied sage grouse using mitochondrial control region sequences. *Auk*, **116**, 819–824.
- Luikart G, Cornuet J (1998) Empirical evaluation of a test for identifying recently bottlenecked populations from allele frequency data. *Conservation Biology*, **12**, 228–237.
- Pemberton JM, Slate J, Bancroft R, Barrett JA (1995) Nonamplifying alleles at microsatellite loci: a caution for parentage and population studies. *Molecular Ecology*, **4**, 249–252.
- Piertney SB, Dallas JF (1997) Isolation and characterization of hypervariable microsatellites in the red grouse *Lagopus lagopus scoticus*. *Molecular Ecology*, **6**, 93–95.
- Quinn TW (1992) The genetic legacy of Mother Goose—phylogeographic patterns of lesser snow goose *Chen carulescens carulescens* maternal lineages. *Molecular Ecology*, **1**, 105–117.
- Quinn TW, White BN (1987) Identification of restriction-fragment-length polymorphisms in genomic DNA of the lesser snow goose (*Anser carulescens carulescens*). *Molecular Biology and Evolution*, **4**, 126–143.
- Sambrook J, Fritsch EF, Maniatis T (1989) *Molecular Cloning: a Laboratory Manual*, 2nd edn. Cold Spring Harbor Laboratory Press, New York.
- Schneider S, Kueffer J, Roessli D, Excoffier L (1997) *ARLEQUIN, Version 1.1: a Software for Population Genetic Data Analysis*. Genetics and Biometry Laboratory, University of Geneva, Switzerland.
- Swofford DL (1991) *PAUP: Phylogenetic Analysis Using Parsimony*, Version 3.0. Distributed by the Illinois Natural History Survey, Champaign.
- Takezaki N, Nei M (1996) Genetic distances and reconstruction of phylogenetic trees from microsatellite DNA. *Genetics*, **144**, 389–399.
- Tamura K (1992) Estimation of the number of nucleotide substitutions when there are strong transition–transversion and G+C content biases. *Molecular Biology and Evolution*, **9**, 678–687.
- Tjur T (1998) Nonlinear regression, quasi likelihood, and overdispersion in generalized linear models. *American Statistician*, **52**, 222–227.
- Young JR (1994) *Sexual selection of sage grouse*. PhD Dissertation, Purdue University.
- Young JR, Hupp JW, Bradbury JW, Braun CE (1994) Phenotypic divergence of secondary sexual traits among sage grouse, *Centrocercus urophasianus*, populations. *Animal Behavior*, **47**, 1353–1362.

---

This paper is part of Sara Oyler-McCance's PhD dissertation, which investigated the effects of habitat loss and fragmentation on Gunnison sage grouse. Dr Nate Kahn and Dr Tom Quinn performed this work at the University of Denver, as part of their research into population genetics. Dr Ken Burnham works as a statistician applying and developing statistical theory in ecology and wildlife studies. Dr Clait Braun works for the Colorado Division of Wildlife and has studied sage grouse in Colorado for 30 years.

---